

3/16 Round Spacers

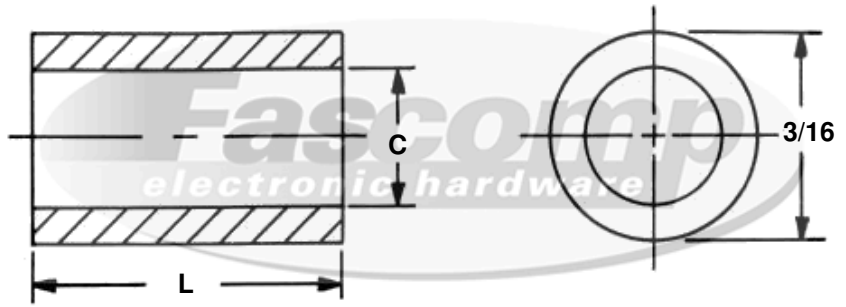

Create a part number:

Length	Clearance	Material	Finish
FCXXXX	XX	XX	XX
_____ - _____ - _____ - _____			

Hex Code Table		
✓	FMXXXX	Length (L)
	FC1107	1/8
	FC1108	3/16
	FC1109	1/4
	FC1110	5/16
	FC1111	3/8
	FC1112	7/16
	FC1113	1/2
	FC1114	9/16
	FC1115	5/8
	FC1116	11/16
	FC1117	3/4
	FC1118	13/16
	FC1119	7/8
	FC1120	15/16
	FC1121	1

Hole Clearance Code (XX)		
✓	Code (XX)	C + .010
	2	.090
	4	.115
	6	.140
	8	.166

Material		
✓	Material Code (XX)	
	A	Aluminum
	B	Brass
	S	Steel
	SS	Stainless Steel
	N	Nylon

✓	Compatible Finish (XX)	
	A, B, S, SS	0 - Plain
	B, S	5 - Nickel Plate (QQ-N-290)
	A	6 - Iridite #14 Gold (MIL-C-5541E)
	A	7 - Iridite Clear (MIL-C-5541E)
	A	9 - Alodine 1200
	B, S	12 - Zinc Clear (ASTM-B-633)
	B, S	16 - Electro Tin (MIL-T-10727 TYPE 1)
	SS	20 - Passivation (MIL-F-14072D)
	A	22 - Clear Anodize (MIL-A-8625-TYPE2) (Sulphuric) Hot Water Seal (Clear)
	A	24 - Black Anodize (MIL-A-8625)
	B, S, SS	26 - Black Oxide
	B, S	28 - Zinc Yellow (ASTM-B-633)



Tolerances
Unless otherwise Specified
 .xxx +/- .005
 .xx +/- .010
 Angular +/- 1 Degree
 Linear +/- .005
Break all sharp edges

Source Control Drawing:
 To be produced by
 Fascomp Electronic Hardware

This document is the property of Fascomp Inc. and shall not be reproduced, distributed, or used as a basis for manufacturing without written permission from Fascomp Inc.